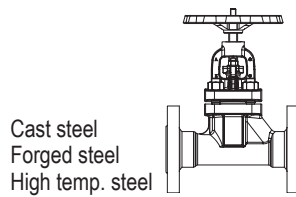


Stop valve with gland seal - metallic sealing  
 DN 10 - 100

**ARI-STOBU® -**  
**Straight through with flanges**

- Rising handwheel
- TRB 801 Annex II No. 45



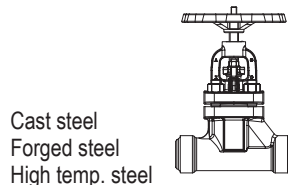
Cast steel  
 Forged steel  
 High temp. steel

**Fig. 006**

Page 2+3

**ARI-STOBU® -**  
**Straight through with butt weld ends**

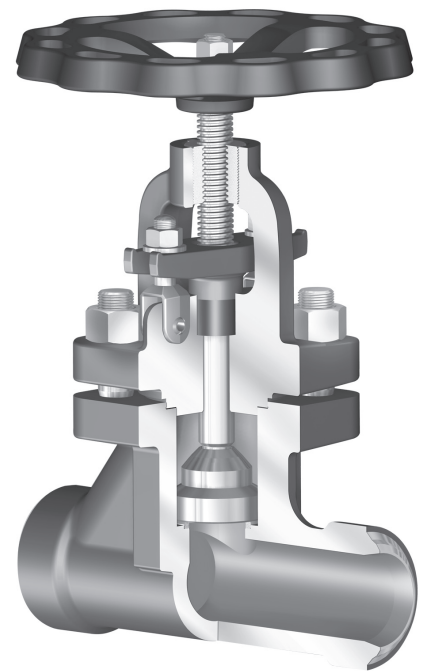
- Rising handwheel
- TRB 801 Annex II No. 45



Cast steel  
 Forged steel  
 High temp. steel

**Fig. 005**

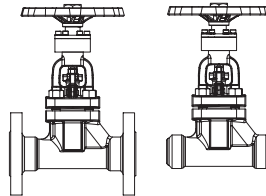
Page 4+5



**Fig. 005**

**ARI-STOBU® -**

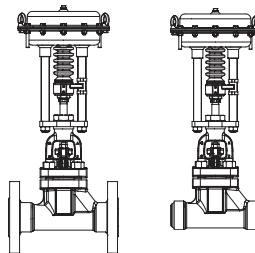
- Option: non-rising handwheel



Page 6+7

**ARI-STOBU® -**  
**Pneumatic actuator**  
**ARI-DP**

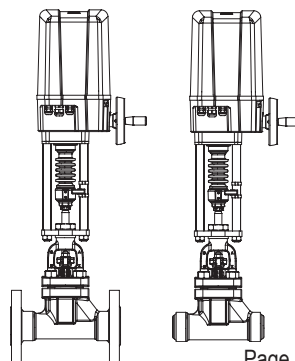
- Reversible pneumatic actuator
- Actuator with rolling diaphragm
- Air supply pressure max. 6 bar
- Stem protection by bellow
- Maintenance-free O-ring sealing



Page 8

**ARI-STOBU® -**  
**Electric actuator**  
**ARI-PREMIO**  
**ARI-PREMIO-Plus**

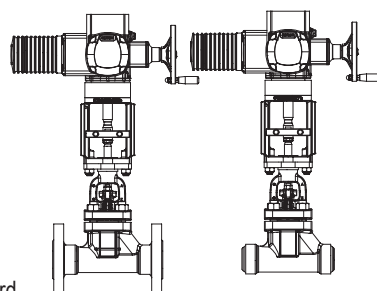
- Enclosure IP 65
- 2 torque switches
- Handwheel
- Additional devices available, e.g. potentiometer



Page 12

**ARI-STOBU® -**  
**Electric actuator**  
**AUMA SA**

- Electric multiturn actuator, capable of high closing pressures
- Enclosure IP 67
- 2 torque switches
- 2 travel switches
- Handwheel
- Overheating protection for motor as standard
- Additional devices available, e.g. potentiometer



Page 14 + 15

**Features:**

- Proven technology
- Plug hardened/stellited
- Seat stellitert
- Stem with roll hardened thread
- Burnished stem
- High-tensile gland packing
- Bonnet top with threaded bushing
- Pivot mounted bolts
- DN 10-50: Back seat (for DN65-100 optional)
- Bonnet sealing inside and outside chambered

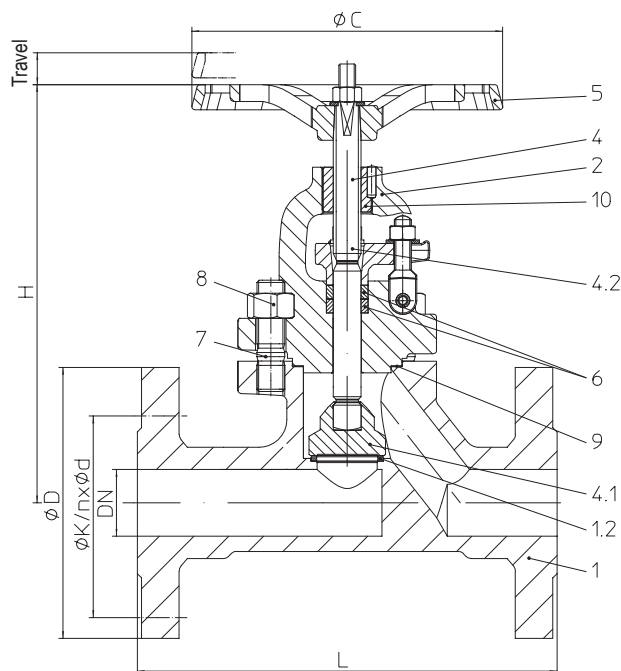
**Stop valve - straight through with flanges and gland seal (Forged steel, High temperature steel)**


Figure	Nominal pressure	Material	Nominal diameter
48.006....40	PN63-160	1.0460	DN10-40
46.006....40	PN63	1.0460	DN50
48.006....40	PN100-160	1.0460	DN50
88.006....81	PN63-160	1.7335	DN10-40
86.006....81	PN63	1.7335	DN50
88.006....81	PN100-160	1.7335	DN50

Larger nominal diameters refer to page 3.

**Options: non-rising handwheel** (refer to page 6)

Parts				
Pos.	Ers.	Description	Fig. 46./48.006....40	Fig. 86./88.006....81
1		Body	P250 GH, 1.0460	13CrMo4-5, 1.7335
1.2		Seat	Stellit 21	
2		Bonnet	P250 GH, 1.0460	13CrMo4-5, 1.7335
4	x (unit)	Spindle unit		
4.1		Plug	X20Cr13+QT, 1.4021+QT (hardened)	13CrMo4-5, 1.7335 / Stellit 6
4.2		Stem	X20Cr13+QT, 1.4021+QT (burnished)	X39CrMo17-1+QT, 1.4122+QT (burnished)
5		Handwheel	EN-GJS-400-15, EN-JS1030 (FE 13 epoxy-coating)	
6	x	Packing ring	Pure graphite	
7		Stud	21CrMoV 5-7, 1.7709	
8		Hexagon nut	21CrMoV 5-7, 1.7709	
9	x	Gasket	Pure graphite (CrNi laminated with graphite)	
10		Insert nuts	11SMn30+C, 1.0715+C (nitrated)	
L Spare parts				

DN	10	15	20	25	32	40	50
----	----	----	----	----	----	----	----

Face-to-face dimension FTF serie 2 acc. to DIN EN 558		Standard-flange dimensions refer to page 16						
L	(mm)	210	210	230	230	260	260	300

Dimensions								
H	(mm)	228	228	228	228	292	292	300
ØC	(mm)	180	180	180	180	225	225	225
Travel	(mm)	11	11	11	11	17	17	21
Kvs-value	(m³/h)	2,7	4,2	6,4	8,6	21,8	24,2	33
Zeta-value	--	2,19	4,58	6,24	8,43	3,52	6,98	9,16
Zeta-value ... range of tolerance for Kvs-values acc. to VDI/VDE 2173								

Weights								
46./86.006	(kg)	--	--	--	--	--	--	26
48./88.006	(kg)	8,7	8,9	10,5	11,5	19	21	27

Larger nominal diameters refer to page 3.

Information / restriction of technical rules need to be observed!

 Operating and installation instructions can be downloaded at [www.ari-armaturen.com](http://www.ari-armaturen.com).

The engineer, designing a system or a plant, is responsible for the selection of the correct valve.

Resistance and fitness must be verified (or contact the manufacturer for information).

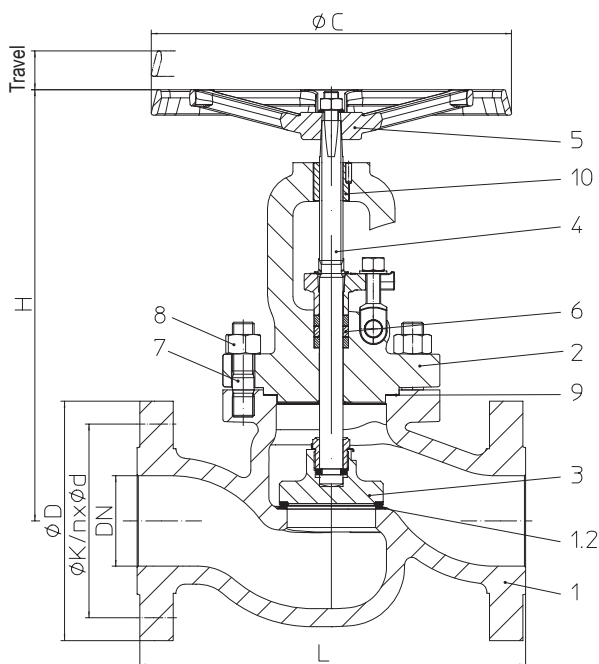
**Stop valve - straight through with flanges and gland seal (Cast steel, High temperature cast steel)**


Figure	Nominal pressure	Material	Nominal diameter
36.006...30	PN63	1.0619+N	DN65-100
37.006...30	PN100	1.0619+N	DN65-100
38.006...30	PN160	1.0619+N	DN65-100

86.006...89	PN63	1.7357	DN65-100
87.006...89	PN100	1.7357	DN65-100
88.006...89	PN160	1.7357	DN65-100

DN125-150 on request.  
Smaller nominal diameters refer to page 2.

**At high differential pressures a balancing plug is necessary!** (refer to page 19)

Parts				
Pos.	Ers.	Description	Fig. 36./37./38.006...30	Fig. 86./87./88.006...89
1		Body	GP240GH+N, 1.0619+N	G17CrMo5-5, 1.7357
1.2		Seat	Stellit 21	
2		Bonnet	GP240GH+N, 1.0619+N	G17CrMo5-5, 1.7357
3	x	Plug	P250 GH, 1.0460 / Stellit 6	13CrMo4-5, 1.7335 / Stellit 6
4	x	Stem	X39CrMo17-1+QT, 1.4122+QT (burnished)	
5		Handwheel	EN-GJS-400-15, EN-JS1030 (FE 13 epoxy-coating)	
6	x	Packing ring	Pure graphite	
7		Stud	21CrMoV 5-7, 1.7709	
8		Hexagon nut	21CrMoV 5-7, 1.7709	
9	x	Gasket	Pure graphite (CrNi laminated with graphite)	
10		Insert nuts	11SMn30+C, 1.0715+C (nitrated)	
L Spare parts				

DN	65	80	100	125	150
----	----	----	-----	-----	-----

Face-to-face dimension FTF serie 2 acc. to DIN EN 558					Standard-flange dimensions refer to page 16	
L	(mm)	340	380	430	on request	

Dimensions						
H	(mm)	395	426	477	on request	
ØC	(mm)	300	300	400		
Travel	(mm)	27	32	39		
Kvs-value	(m³/h)	71	122	162		
Zeta-value	--	5,65	4,39	6,08		
Zeta-value ... range of tolerance for Kvs-values acc. to VDI/VDE 2173						

Weights						
36./86.006	(kg)	40	50	76,5	on request	
37./87.006	(kg)	43,5	60	90,1		
38./88.006	(kg)	44,7	61,5	92,5		
Smaller nominal diameters refer to page 2.						

Information / restriction of technical rules need to be observed!

Operating and installation instructions can be downloaded at [www.ari-armaturen.com](http://www.ari-armaturen.com).

The engineer, designing a system or a plant, is responsible for the selection of the correct valve.

Resistance and fitness must be verified (or contact the manufacturer for information).

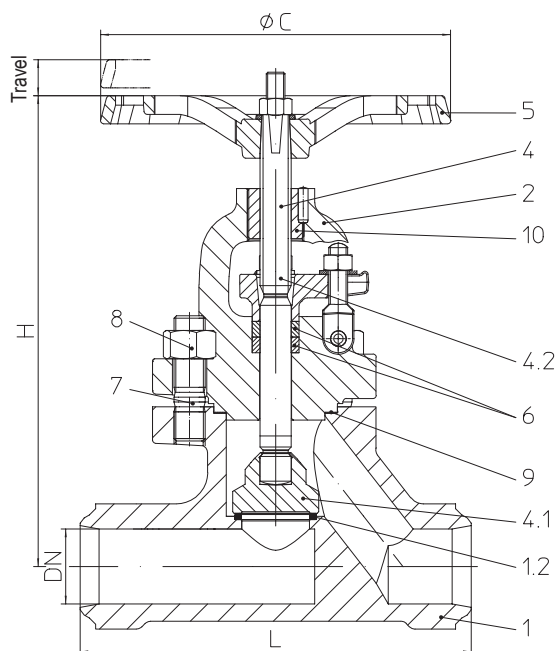
**Stop valve - straight through with butt weld ends and gland seal (Forged steel, High temperature steel)**


Figure	Nominal pressure	Material	Nominal diameter
48.005...40	PN160	1.0460	DN10-50

88.005...80	PN160	1.5415	DN10-50
88.005...81	PN160	1.7335	DN10-50

Larger nominal diameters refer to page 5.

Butt weld ends according to DIN EN 12627 (refer to page 16)

Options: non-rising handwheel (refer to page 7)

Parts					
Pos.	Ers.	Description	Fig. 48.005...40	Fig. 88.005...80	Fig. 88.005...81
1		Body	P250 GH, 1.0460	16Mo3, 1.5415	13CrMo4-5, 1.7335
1.2		Seat	Stellit 21		
2		Bonnet	P250 GH, 1.0460	16Mo3, 1.5415	13CrMo4-5, 1.7335
4		Spindle unit			
4.1	x (unit)	Plug	X20Cr13+QT, 1.4021+QT hardened)	13CrMo4-5, 1.7335 / Stellit 6	
4.2		Stem	X20Cr13+QT, 1.4021+QT burnished)	X39CrMo17-1+QT, 1.4122+QT (burnished)	
5		Handwheel	EN-GJS-400-15, EN-JS1030 (FE 13 epoxy-coating)		
6	x	Packing ring	Pure graphite		
7		Stud	21CrMoV 5-7, 1.7709		
8		Hexagon nut	21CrMoV 5-7, 1.7709		
9	x	Gasket	Pure graphite (CrNi laminated with graphite)		
10		Insert nuts	11SMn30+C, 1.0715+C (nitrated)		
L Spare parts					

DN	10	15	20	25	32	40	50
----	----	----	----	----	----	----	----

Face-to-face dimension ETE serie 65 acc. to DIN EN 12982								
L	(mm)	150	150	150	160	180	210	250

Dimensions								
H	(mm)	228	228	228	228	292	292	300
ØC	(mm)	180	180	180	180	225	225	225
Travel	(mm)	11	11	11	11	17	17	21
Kvs-value	(m³/h)	2,7	4,2	6,4	8,6	21,8	24,2	33
Zeta-value	--	2,19	4,58	6,24	8,43	3,52	6,89	9,16
Zeta-value ... range of tolerance for Kvs-values acc. to VDI/VDE 2173								

Weights								
48.005 / 88.005	(kg)	6,5	6,5	6,5	6,6	13,2	13,2	16,2
Larger nominal diameters refer to page 5.								

Information / restriction of technical rules need to be observed!

Operating and installation instructions can be downloaded at [www.ari-armaturen.com](http://www.ari-armaturen.com).

The engineer, designing a system or a plant, is responsible for the selection of the correct valve.

Resistance and fitness must be verified (or contact the manufacturer for information).

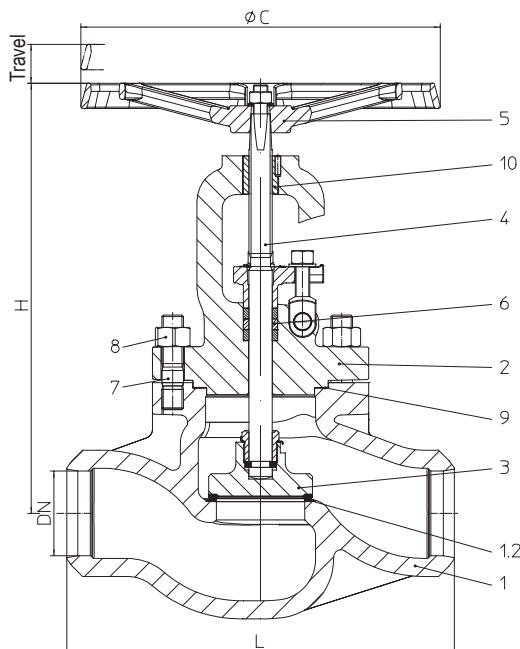
**Stop valve - straight through with butt weld ends and gland seal (Cast steel, High temperature cast steel)**


Figure	Nominal pressure	Material	Nominal diameter
37.005....30	PN100	1.0619+N	DN65-100
38.005....30	PN160	1.0619+N	DN65-100

87.005....89	PN100	1.7357	DN65-100
88.005....89	PN160	1.7357	DN65-100

DN125-150 on request.  
Smaller nominal diameters refer to page 4.

Butt weld ends according to DIN EN 12627 (refer to page 16)

At high differential pressures a balancing plug is necessary! (refer to page 19)

Parts				
Pos.	Ers.	Description	Fig. 37./38.005....30	Fig. 87./88.005....89
1		Body	GP240GH+N, 1.0619+N	G17CrMo5-5, 1.7357
1.2		Seat	Stellit 21	
2		Bonnet	GP240GH+N, 1.0619+N	G17CrMo5-5, 1.7357
3	x	Plug	P250 GH, 1.0460 / Stellit 6	13CrMo4-5, 1.7335 / Stellit 6
4	x	Stem	X39CrMo17-1+QT, 1.4122+QT (burnished)	
5		Handwheel	EN-GJS-400-15, EN-JS1030 (FE 13 epoxy-coating)	
6	x	Packing ring	Pure graphite	
7		Stud	21CrMoV 5-7, 1.7709	
8		Hexagon nut	21CrMoV 5-7, 1.7709	
9	x	Gasket	Pure graphite (CrNi laminated with graphite)	
10		Insert nuts	11SMn30+C, 1.0715+C (nitrated)	
L Spare parts				

DN	65	80	100	125	150
----	----	----	-----	-----	-----

Face-to-face dimension ETE serie 65 acc. to DIN EN 12982					
L	(mm)	340	380	430	on request

Dimensions					
H	(mm)	395	426	477	on request
ØC	(mm)	300	300	400	
Travel	(mm)	27	32	39	
Kvs-value	(m³/h)	71	122	162	
Zeta-value	--	5,65	4,39	6,08	
Zeta-value ... range of tolerance for Kvs-values acc. to VDI/VDE 2173					

Weights					
37./38./87./88.005	(kg)	38,5	46,4	72	on request
Smaller nominal diameters refer to page 4.					

Information / restriction of technical rules need to be observed!

Operating and installation instructions can be downloaded at [www.ari-armaturen.com](http://www.ari-armaturen.com).

The engineer, designing a system or a plant, is responsible for the selection of the correct valve.

Resistance and fitness must be verified (or contact the manufacturer for information).

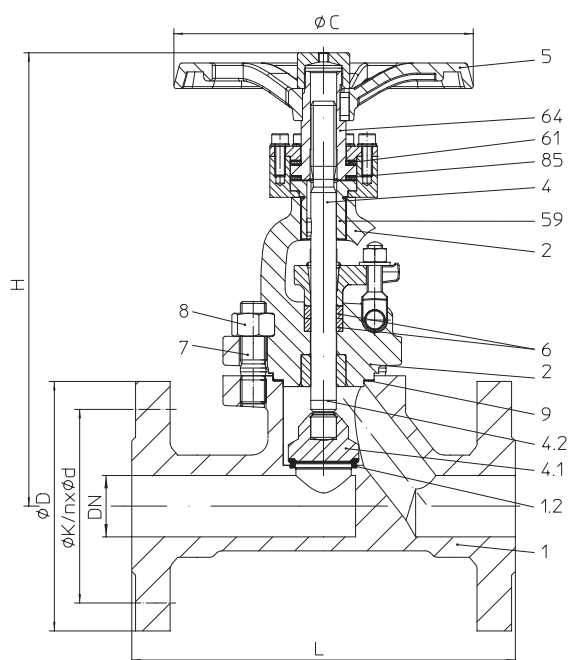
**Stop valve - straight through with flanges and gland seal (Forged steel, High temperature steel)**


Figure	Nominal pressure	Material	Nominal diameter
48.006...40...1	PN63-160	1.0460	DN10-40
46.006...40...1	PN63	1.0460	DN50
48.006...40...1	PN100-160	1.0460	DN50
88.006...81...1	PN63-160	1.7335	DN10-40
86.006...81...1	PN63	1.7335	DN50
88.006...81...1	PN100-160	1.7335	DN50

Easy conversion to connection F10 acc. to ISO 5210 group (lock bush) B1

Parts				
Pos.	Ers.	Description	Fig. 46./48.006...40...1	Fig. 86./88.006...81...1
1		Body	P250 GH, 1.0460	13CrMo4-5, 1.7335
1.2		Seat	Stellit 21	
2		Bonnet	P250 GH, 1.0460	13CrMo4-5, 1.7335
4		Spindle unit		
4.1	x	Plug	X20Cr13+QT, 1.4021+QT (hardened)	13CrMo4-5, 1.7335 / Stellit 6
4.2		Stem	X20Cr13+QT, 1.4021+QT (burnished)	X39CrMo17-1+QT, 1.4122+QT (burnished)
5		Handwheel	EN-GJL-250, EN-JL1040 (FE 13 epoxy-coating)	
6	x	Packing ring	Pure graphite	
7		Stud	21CrMoV 5-7, 1.7709	
8		Hexagon nut	21CrMoV 5-7, 1.7709	
9	x	Gasket	Pure graphite (CrNi laminated with graphite)	
59		Screw joint	11SMn30+C, 1.0715+C (nitrated)	
61 / 85		Nadellager	St	
64		Insert nuts	11SMn30+C, 1.0715+C (nitrated)	
L Spare parts				

DN	10	15	20	25	32	40	50
----	----	----	----	----	----	----	----

Face-to-face dimension FTF serie 2 acc. to DIN EN 558 Standard-flange dimensions refer to page 16

L	(mm)	210	210	230	230	260	260	300
---	------	-----	-----	-----	-----	-----	-----	-----

Dimensions								
H	(mm)	273	273	273	273	334	334	347
ØC	(mm)	180	180	180	180	225	225	225
Travel	(mm)	11	11	11	11	17	17	21
Kvs-value	(m³/h)	2,7	4,2	6,4	8,6	21,8	24,2	33
Zeta-value	--	2,19	4,58	6,24	8,43	3,52	6,98	9,16

Zeta-value ... range of tolerance for Kvs-values acc. to VDI/VDE 2173

Weights								
46./86.006 ...1	(kg)	--	--	--	--	--	--	29
48./88.006 ...1	(kg)	10,7	10,9	12,5	13,5	22	24	30

Information / restriction of technical rules need to be observed!

Operating and installation instructions can be downloaded at [www.ari-armaturen.com](http://www.ari-armaturen.com).

The engineer, designing a system or a plant, is responsible for the selection of the correct valve.

Resistance and fitness must be verified (or contact the manufacturer for information).

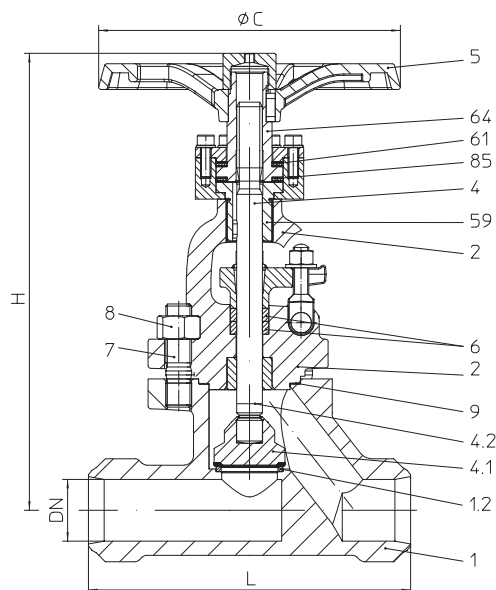
**Stop valve - straight through with butt weld ends and gland seal (Forged steel, High temperature steel)**


Figure	Nominal pressure	Material	Nominal diameter
48.005...40...1	PN160	1.0460	DN10-50

88.005...80...1	PN160	1.5415	DN10-50
-----------------	-------	--------	---------

88.005...81...1	PN160	1.7335	DN10-50
-----------------	-------	--------	---------

Butt weld ends according to DIN EN 12627 (refer to page 16)

Easy conversion to connection F10 acc. to ISO 5210 group (lock bush) B1

Parts					
Pos.	Ers.	Description	Fig. 48.005...40...1	Fig. 88.005...80...1	Fig. 88.005...81...1
1		Body	P250 GH, 1.0460	16Mo3, 1.5415	13CrMo4-5, 1.7335
1.2		Seat	Stellit 21		
2		Bonnet	P250 GH, 1.0460	16Mo3, 1.5415	13CrMo4-5, 1.7335
4		Spindle unit			
4.1	x (unit)	Plug	X20Cr13+QT, 1.4021+QT hardened)	13CrMo4-5, 1.7335 / Stellit 6	
4.2		Stem	X20Cr13+QT, 1.4021+QT burnished)	X39CrMo17-1+QT, 1.4122+QT (burnished)	
5		Handwheel	EN-GJL-250, EN-JL1040 (FE 13 epoxy-coating)		
6	x	Packing ring	Pure graphite		
7		Stud	21CrMoV 5-7, 1.7709		
8		Hexagon nut	21CrMoV 5-7, 1.7709		
9	x	Gasket	Pure graphite (CrNi laminated with graphite)		
59		Screw joint	11SMn30+C, 1.0715+C (nitrated)		
61 / 85		Nadellager	St		
64		Insert nuts	11SMn30+C, 1.0715+C (nitrated)		
		L Spare parts			

DN	10	15	20	25	32	40	50
----	----	----	----	----	----	----	----

**Face-to-face dimension ETE serie 65 acc. to DIN EN 12982**

L	(mm)	150	150	150	160	180	210	250
---	------	-----	-----	-----	-----	-----	-----	-----

**Dimensions**

	(mm)	273	273	273	273	334	334	347
H	(mm)	180	180	180	180	225	225	225
ØC	(mm)	11	11	11	11	17	17	21
Travel	(mm)	2,7	4,2	6,4	8,6	21,8	24,2	33
Kvs-value	(m³/h)	2,19	4,58	6,24	8,43	3,52	6,89	9,16
Zeta-value	--	Zeta-value ... range of tolerance for Kvs-values acc. to VDI/VDE 2173						

**Weights**

48.005 / 88.005...1	(kg)	8,5	8,5	8,5	8,5	16,2	16,2	19,2
---------------------	------	-----	-----	-----	-----	------	------	------

Information / restriction of technical rules need to be observed!

Operating and installation instructions can be downloaded at [www.ari-armaturen.com](http://www.ari-armaturen.com).

The engineer, designing a system or a plant, is responsible for the selection of the correct valve.

Resistance and fitness must be verified (or contact the manufacturer for information).

## Stop valve in straightway form with gland packing with pneumatic actuator ARI-DP

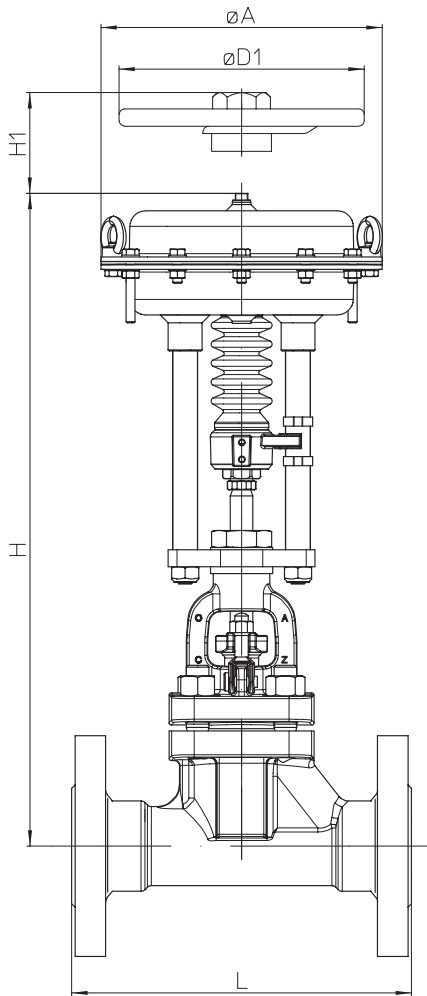


Fig. 006

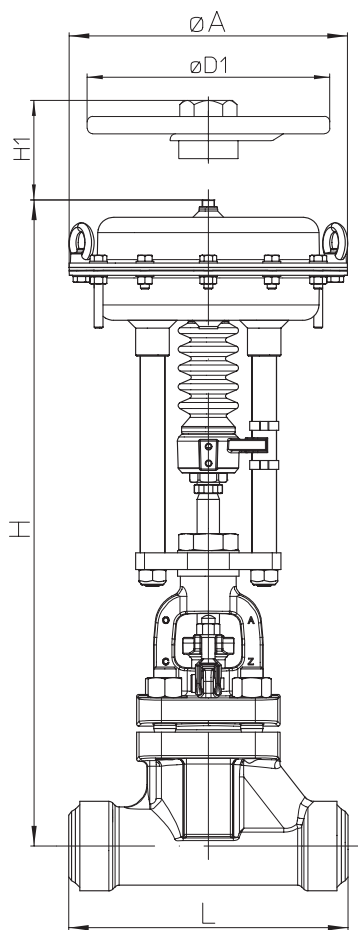


Fig. 005

Actuator data		DP32	DP33	DP34
Ø A	(mm)	250	300	405
Eff. diaphragm area	(cm <sup>2</sup> )	250	400	800
Ø D1	(mm)	225	300	400
H1	(mm)	270	284	442
Weight	(kg)	5		17

**Heights and weights**

Technical data and accessories of actuators: refer to actuator data sheet

DN				10	15	20	25	32	40	50	65	80	100	125	150
DP32	Fig. 006	H	(mm)	515	515	515	515	--	--	--	--	--	--	--	--
		PN63-160	(kg)	18	18,2	19,8	20,8	--	--	--	--	--	--	--	--
	Fig. 005	H	(mm)	515	515	515	515	--	--	--	--	--	--	--	--
		PN63-160	(kg)	15,7	15,7	15,7	15,9	--	--	--	--	--	--	--	--
DP33	Fig. 006	H	(mm)	568	568	568	568	--	--	--	--	--	--	--	--
		PN63-160	(kg)	24	24,2	25,8	26,8	--	--	--	--	--	--	--	--
	Fig. 005	H	(mm)	568	568	568	568	--	--	--	--	--	--	--	--
		PN63-160	(kg)	21,7	21,7	21,7	21,9	--	--	--	--	--	--	--	--
DP34	Fig. 006	H	(mm)	--	--	--	--	738	738	751	on request				
		PN63-160	(kg)	--	--	--	--	65	67	72,5					
	Fig. 005	H	(mm)	--	--	--	--	738	738	751					
		PN63-160	(kg)	--	--	--	--	59,2	59,2	61,7					

Fig. 006: Face-to-face dimension FTF serie 2 acc. to DIN EN 558


Standard-flange dimensions refer to page 16

Fig. 005: Face-to-face dimension ETE serie 65 acc. to DIN EN 12982


Valves with butt weld ends refer to page 16



**Spring closes on air failure (Extended stem on air failure)**

DN		10	15	20	25
Kvs-value	(m <sup>3</sup> /h)	2,7	4,2	6,4	8,6
max. differential press. <sup>1)</sup>	(bar)	2	2	2	2
Travel	(mm)	11	11	11	11
 <b>DP32</b> <b>250 cm<sup>2</sup></b>	Spring range (bar) 2-3,3 Air supply pressure min. (bar) 4,5 (bar)	40	40	40	40

**Spring opens on air failure (Retracted stem on air failure)**


DN		10	15	20	25
Kvs-value	(m <sup>3</sup> /h)	2,7	4,2	6,4	8,6
max. differential press. <sup>1)</sup>	(bar)	2	2	2	2
Travel	(mm)	11	11	11	11
 <b>DP32</b> <b>250 cm<sup>2</sup></b>	Air supply pressure min. (bar) 4,5 (bar)	40	40	40	40
	Air supply pressure min. (bar) 6 (bar)	60	60	60	60

**max. permissible closing pressures** on flow-to-open P2 = 0.  
 Observe restrictions by Pressure-temperature-ratings, refer to page 17.


<sup>1)</sup> Max. differential pressure drop bei Flow

Air supply pressure max. to actuator: 6 bar

## Spring closes on air failure (Extended stem on air failure)

DN		10	15	20	25
Kvs-value	(m <sup>3</sup> /h)	2,7	4,2	6,4	8,6
max. differential press. <sup>1)</sup>	(bar)	2	2	2	2
Travel	(mm)	11	11	11	11
 DP33 400 cm <sup>2</sup>	Spring range (bar)	60	60	60	60
	Air supply pressure min. (bar)				

## Spring opens on air failure (Retracted stem on air failure)

DN		10	15	20	25
Kvs-value	(m <sup>3</sup> /h)	2,7	4,2	6,4	8,6
max. differential press. <sup>1)</sup>	(bar)	2	2	2	2
Travel	(mm)	11	11	11	11
 DP33 400 cm <sup>2</sup>	Air supply pressure min. (bar)	60	60	60	60
		80	80	80	80
	6				


**max. permissible closing pressures** on flow-to-open P<sub>2</sub> = 0.

Observe restrictions by Pressure-temperature-ratings, refer to page 17.


<sup>1)</sup> Max. differential pressure drop bei Flow

Air supply pressure max. to actuator: 6 bar

**Spring closes on air failure (Extended stem on air failure)**

DN		32	40	50	65	80	100	125	150
Kvs-value	(m <sup>3</sup> /h)	21,8	24,2	33	on request				
max. differential press. <sup>1)</sup>	(bar)	2	2	2					
Travel	(mm)	17	17	21					
 .DP34 800 cm <sup>2</sup>	Spring range (bar) 2,4-3,6 Air supply pressure min. (bar) 4,5 (bar)	60	60	50					

**Spring opens on air failure (Retracted stem on air failure)**

DN		32	40	50	65	80	100	125	150
Kvs-value	(m <sup>3</sup> /h)	21,8	24,2	33	on request				
max. differential press. <sup>1)</sup>	(bar)	2	2	2					
Travel	(mm)	17	17	21					
 DP34 800 cm <sup>2</sup>	Air supply pressure min. (bar) 4,5 (bar)	65	65	60					
	Air supply pressure min. (bar) 6 (bar)	80	80	70					

**max. permissible closing pressures** on flow-to-open P2 = 0.  
 Observe restrictions by Pressure-temperature-ratings, refer to page 17.

<sup>1)</sup> Max. differential pressure drop bei Flow

Air supply pressure max. to actuator: 6 bar

## Stop valve in straightway form with gland packing with electric actuator ARI-PREMIO / PREMIO-Plus

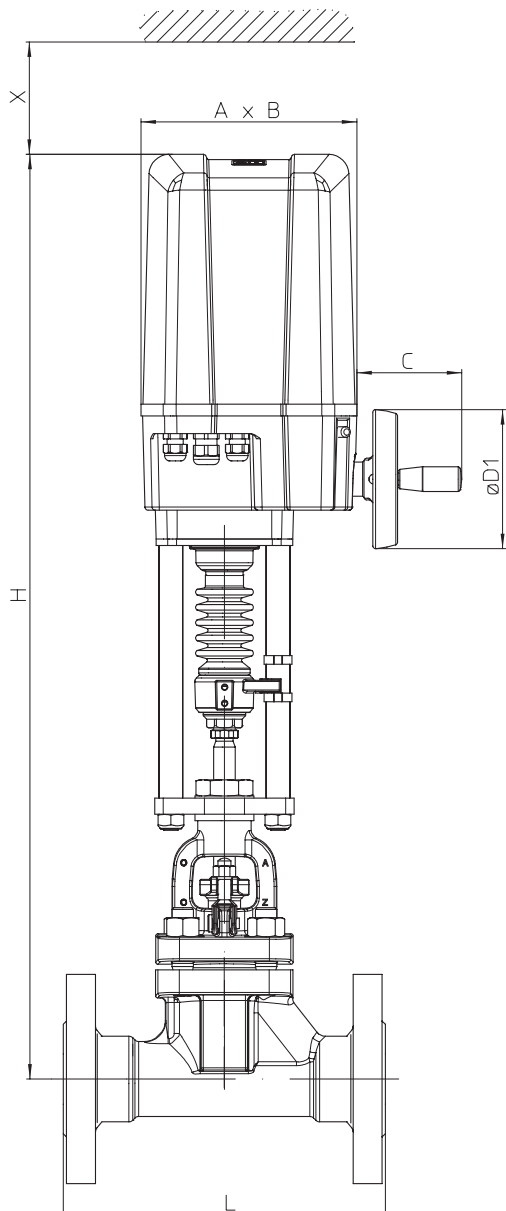


Fig. 006

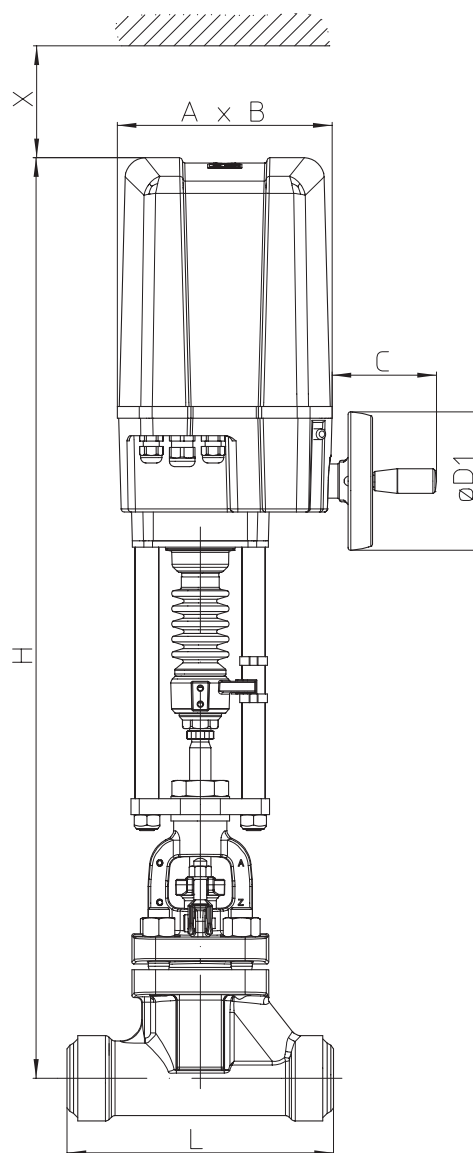


Fig. 005

Actuator data		5 kN	12 - 15 kN
A	(mm)	165	202
B	(mm)	150	176
C	(mm)	50	97
Ø D1	(mm)	90	130
X	(mm)	150	200

**Heights and weights**

Technical data and accessories of actuators: refer to actuator data sheet

DN			10	15	20	25	32	40	50	65	80	100	125	150
Fig. 006	H	(mm)	651	651	651	651	--	--	--	--	--	--	--	--
	5 kN	PN63-160	(kg)	15	15,2	16,8	17,8	--	--	--	--	--	--	--
	H	(mm)	801	801	801	801	851	851	864	on request				
	12 kN / 15 kN	PN63-160	(kg)	19,5	19,7	21,3	22,3	30,5	32,5	38	on request			
Face-to-face dimension FTF serie 2 acc. to DIN EN 558										Standard-flange dimensions refer to page 16				

Fig. 005	H	(mm)	651	651	651	651	--	--	--	--	--	--	--	--
	5 kN	PN63-160	(kg)	12,7	12,7	12,7	12,9	--	--	--	--	--	--	--
	H	(mm)	801	801	801	801	851	851	864	on request				
	12 kN / 15 kN	PN63-160	(kg)	17,2	17,2	17,2	17,4	24,7	24,7	27,2	on request			
Face-to-face dimension ETE serie 65 acc. to DIN EN 12982										Valves with butt weld ends refer to page 16				

DN		10	15	20	25	32	40	50	65	80	100	125	150	
Kvs-value	(m <sup>3</sup> /h)	2,7	4,2	6,4	8,6	21,8	24,2	33	on request					
max. differential press. <sup>1)</sup>	(bar)	2	2	2	2	2	2	2						
Travel	(mm)	11	11	11	11	17	17	21						
5 kN	Closing pressure	(bar)	30	30	30	30								
	Operating time	(s)	29	29	29	29								
	Control speed	(mm/s)	0,38											
12 kN	Closing pressure	(bar)	60	60	60	60	50	50						40
	Operating time	(s)	29	29	29	29	45	45						45
	Control speed	(mm/s)	0,38											
15 kN	Closing pressure	(bar)	70	70	70	70	60	60						50
	Operating time	(s)	29	29	29	29	45	45						45
	Control speed	(mm/s)	0,38											

**max. permissible closing pressures** on flow-to-open P2 = 0.  
 Observe restrictions by Pressure-temperature-ratings, refer to page 17.

<sup>1)</sup> Max. differential pressure drop bei Flow

Motor voltage: 230V 50Hz  
 Other voltages: 24V 50/60Hz; 115V 50/60Hz; 230V 60Hz  
 Technical data for actuator refer to data sheet ARI-PREMIO.

Indicated operating times with 50Hz.

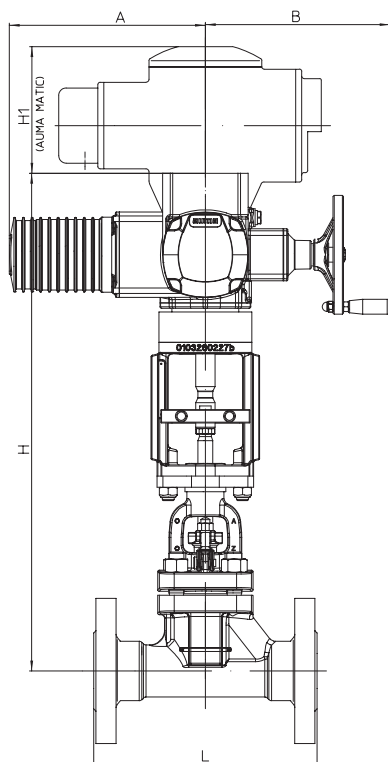
**Stop valve in straightway form with gland packing with electric actuator AUMA**


Fig. 006

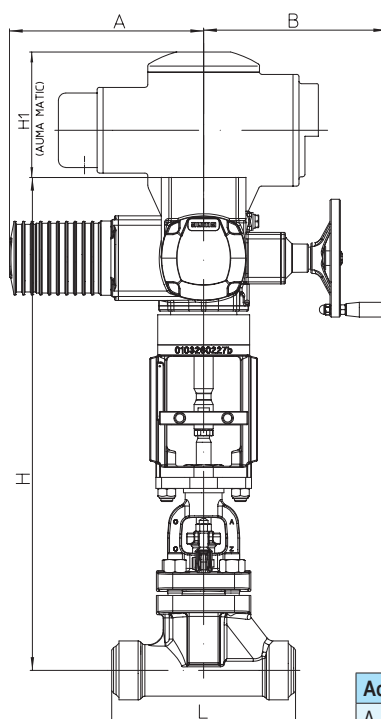


Fig. 005

Connection  
acc. to ISO 5210  
group A

Actuator data		SA 07.6	SA 10.2
A	(mm)	265	283
B	(mm)	249	254
H1 (AUMA MATIC)	(mm)	130	

**Heights and weights**

Technical data and accessories of actuators: refer to actuator data sheet

DN			10	15	20	25	32	40	50	65	80	100	125	150
Fig. 006	H	(mm)	707	707	707	707	758	758	771	--	--	--	--	--
	SA 07.6	PN63-160	(kg)	27,9	28,1	29,7	30,7	39	41	46,5	--	--	--	--
	H	(mm)	--	--	--	--	770	770	783	on request				
	SA 10.2	PN63-160	(kg)	--	--	--	--	43	42					

Face-to-face dimension FTF serie 2 acc. to DIN EN 558

Standard-flange dimensions refer to page 16

Fig. 005	H	(mm)	707	707	707	707	758	758	771	--	--	--	--	--
	SA 07.6	PN63-160	(kg)	25,6	25,6	25,6	25,8	33,2	33,2	35,7	--	--	--	--
	H	(mm)	--	--	--	--	770	770	783	on request				
	SA 10.2	PN63-160	(kg)	--	--	--	--	37,2	37,2					

Face-to-face dimension ETE serie 65 acc. to DIN EN 12982

Valves with butt weld ends refer to page 16

DN		10	15	20	25	32	40	50	65	80	100	125	150	
Kvs-value	(m³/h)	2,7	4,2	6,4	8,6	21,8	24,2	33	on request					
max. differential press. <sup>1)</sup>	(bar)	2	2	2	2	2	2	2						
Travel	(mm)	11	11	11	11	17	17	21						
SA 07.6 Output drive Form A TR 26 x 5 - LH	Closing pressure	(bar)	160	160	160	160	80	80						80
	Torque	(Nm)	30	30	30	30	30	30						30
	Operating time	(s)	8	8	8	8	13	13						15
	Output drive	(rpm)	16	16	16	16	16	16						16
SA 10.2 Output drive Form A TR 26 x 5 - LH	Closing pressure	(bar)					160	160						160
	Torque (Nm)	(Nm)					60	60						60
	Operating time	(s)					13	13						15
	Output drive	(rpm)					16	16	16					

**max. permissible closing pressures** on flow-to-open P2 = 0.

Observe restrictions by Pressure-temperature-ratings, refer to page 17.

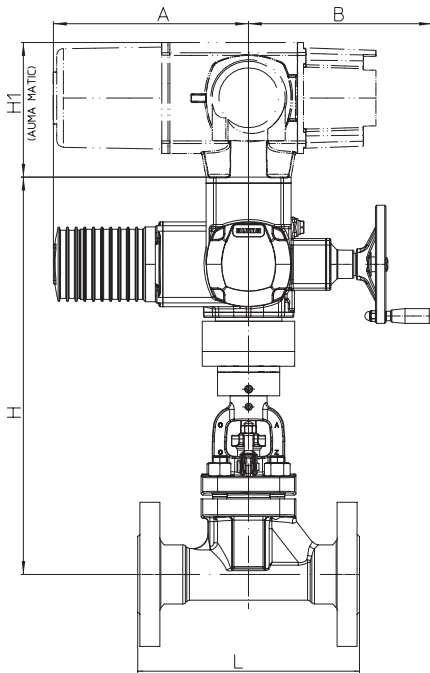
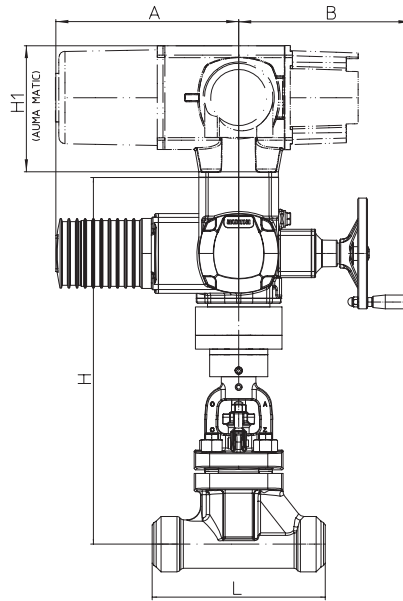
<sup>1)</sup> Max. differential pressure drop bei Flow

Motor voltage: 400V 50Hz 3~

(Other voltages on request)

Technical data for actuator refer to price list.

Indicated operating times with 50Hz.

**Stop valve in straightway form with gland packing with electric actuator AUMA**

**Fig. 006**

**Fig. 005**

Connection F10  
 acc. to ISO 5210  
 group (lock bush) B1

Actuator data		SA 07.6	SA 10.2
A	(mm)	265	283
B	(mm)	249	254
H1 (AUMA MATIC)	(mm)	130	

**Heights and weights**

Technical data and accessories of actuators: refer to actuator data sheet

DN			10	15	20	25	32	40	50	65	80	100	125	150
Fig. 006	H	(mm)	466	466	466	466	520	520	535	--	--	--	--	--
	SA 07.6	PN63-160	(kg)	20,7	20,9	22,5	23,5	42	44	50	--	--	--	--
	H	(mm)	--	--	--	--	520	520	535	on request				
	SA 10.2	PN63-160	(kg)	--	--	--	--	43	42	50,5	on request			

Face-to-face dimension FTF serie 2 acc. to DIN EN 558

Standard-flange dimensions refer to page 16

Fig. 005	H	(mm)	466	466	466	466	520	520	535	--	--	--	--	--
	SA 07.6	PN63-160	(kg)	18,5	18,5	18,5	18,6	26,2	26,2	29,2	--	--	--	--
	H	(mm)	--	--	--	--	520	520	535	on request				
	SA 10.2	PN63-160	(kg)	--	--	--	--	37,2	37,2	39,7	on request			

Face-to-face dimension ETE serie 65 acc. to DIN EN 12982

Valves with butt weld ends refer to page 16

DN			10	15	20	25	32	40	50	65	80	100	125	150
Kvs-value		(m³/h)	2,7	4,2	6,4	8,6	21,8	24,2	33	on request				
max. differential press. <sup>1)</sup>		(bar)	2	2	2	2	2	2	2					
Travel		(mm)	11	11	11	11	17	17	21					
SA 07.6 Abtrieb Form B1	Closing pressure	(bar)	160	160	160	160	80	80	80					
	Torque	(Nm)	30	30	30	30	30	30	30					
	Operating time	(s)	8	8	8	8	13	13	15					
	Output drive	(rpm)	16	16	16	16	16	16	16					
SA 10.2 Abtrieb Form B1	Closing pressure	(bar)					160	160	160					
	Torque (Nm)	(Nm)					60	60	60					
	Operating time	(s)					13	13	15					
	Output drive	(rpm)					16	16	16					

**max. permissible closing pressures** on flow-to-open P2 = 0.

Observe restrictions by Pressure-temperature-ratings, refer to page 17.

<sup>1)</sup> Max. differential pressure drop bei Flow

Motor voltage: 400V 50Hz 3~

(Other voltages on request)

Technical data for actuator refer to price list.

Indicated operating times with 50Hz.

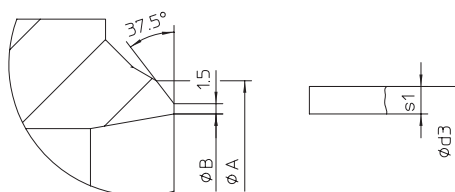
DN	10	15	20	25	32	40	50	65	80	100	125	150
----	----	----	----	----	----	----	----	----	----	-----	-----	-----

Standard-flange dimensions			Flanges according to DIN 2501, Facing acc. to DIN 2526 Form E (Flangeholes / -thickness tol. acc. To DIN 2546/2547/2548)										
PN63	ØD	(mm)	100	105	130	140	155	170	180	205	215	250	on request
PN63	ØK	(mm)	70	75	90	100	110	125	135	160	170	200	
PN63	n x Ød	(mm)	4 x 14	4 x 14	4 x 18	4 x 18	4 x 22	4 x 22	4 x 22	8 x 22	8 x 22	8 x 26	
PN100	ØD	(mm)	100	105	130	140	155	170	195	220	230	265	
PN100	ØK	(mm)	70	75	90	100	110	125	145	170	180	210	
PN100	n x Ød	(mm)	4 x 14	4 x 14	4 x 18	4 x 18	4 x 22	4 x 22	4 x 26	8 x 26	8 x 26	8 x 30	
PN160	ØD	(mm)	100	105	130	140	155	170	195	220	230	265	
PN160	ØK	(mm)	70	75	90	100	110	125	145	170	180	210	
PN160	n x Ød	(mm)	4 x 14	4 x 14	4 x 18	4 x 18	4 x 22	4 x 22	4 x 26	8 x 26	8 x 26	8 x 30	

**Valves with butt weld ends**

L = Face-to-face dimension  
 Edge shaping acc. to DIN EN 25817

Ød3 / s1 = corresponding pipe dimension



DN	10	15	20	25	32	40	50	65	80	100	125	150
----	----	----	----	----	----	----	----	----	----	-----	-----	-----

**Butt weld ends according to DIN EN 12627**

L	(mm)	150	150	150	160	180	210	250	340	380	430	on request		
PN63	ØA (mm)	on request									77		91	117
	ØB (mm)										68,9		80,9	104,3
	Ød3 (mm)										76,1		88,9	114,3
	s1 (mm)										3,6		4	5
PN100	ØA (mm)	on request									77		91	117
	ØB (mm)										68,9		80,9	104,3
	Ød3 (mm)										76,1		88,9	114,3
	s1 (mm)										3,6		4	5
PN160	ØA (mm)	18	22	28	35	44	50	62	77	91	117			
	ØB (mm)	13,2	17,3	22,3	27,3	35,2	41,1	52,3	64,9	76,3	98,3			
	Ød3 (mm)	17,2	21,3	26,9	33,7	42,4	48,3	60,3	76,1	88,9	114,3			
	s1 (mm)	2	2	2,3	3,2	3,6	3,6	4	5,6	6,3	8			

**Face-to-face dimension ETE serie 65 acc. to DIN EN 12982.**

The material used for ARI valves with butt weld ends are:

- P250GH, 1.0460 acc. to DIN EN 10222-2
- 16Mo3, 1.5415 acc. to DIN EN 10222-2
- 13CrMo4-5, 1.7335 acc. to DIN EN 10222-2
- GP240GH+N, 1.0619+N acc. to DIN EN 10213
- G17CrMo5-5, 1.7357 acc. to DIN EN 10213

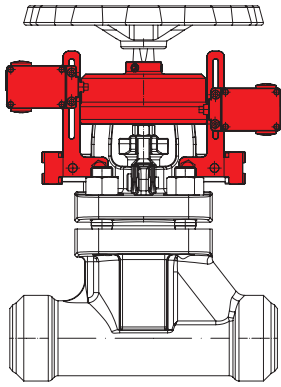


**Pressure-temperature-ratings** Intermediate values for max. permissible operational pressures can be determined by linear interpolation of the given temperature / pressure chart.

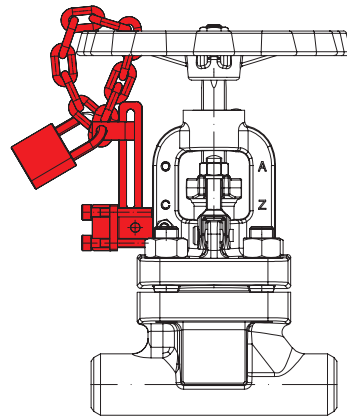
acc. to manufacturers standard			-10°C to 50°C	100°C	200°C	250°C	300°C	350°C	400°C
1.0619+N	63	(bar)	63	55,1	45,9	42	38,1	35,4	34,1
1.0619+N	100	(bar)	100	87,5	72,9	66,7	60,4	56,3	54,2
1.0619+N	160	(bar)	160	140	116,7	106,7	96,7	90	86,7

acc. to manufacturers standard			-10°C to 50°C	120°C	150°C	200°C	250°C	300°C	350°C	400°C	450°C
1.0460	PN 63	(bar)	63	63	58	50	45	40	36	32	24
1.0460	PN 100	(bar)	100	100	90	80	70	60	56	50	38
1.0460	PN 160	(bar)	160	160	145	130	112	96	90	80	60

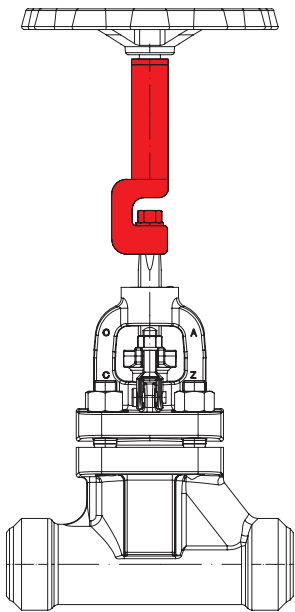
acc. to manufacturers standard			-10°C to 250°C	300°C	350°C	400°C	450°C	500°C	520°C	530°C	540°C	550°C
1.5415	PN 63	(bar)	63	56	50	47	45	29	16	14	--	--
1.5415	PN 100	(bar)	100	87	78	74	70	45	27	22	--	--
1.5415	PN 160	(bar)	160	139	125	118	112	72	43	35	--	--
1.7335	PN 63	(bar)	63	63	61	58	56	47	32	25	20	15
1.7335	PN 100	(bar)	100	100	95	91	87	74	49	38	31	24
1.7335	PN 160	(bar)	160	160	153	146	139	118	79	62	46	35
1.7357	PN 63	(bar)	63	63	60	56,7	53,1	41,1	28,2	23,4	--	--
1.7357	PN 100	(bar)	100	100	95,2	90	84,2	65,2	44,7	37,1	--	--
1.7357	PN 160	(bar)	160	160	152,3	144	134,8	104,3	71,6	59,4	--	--



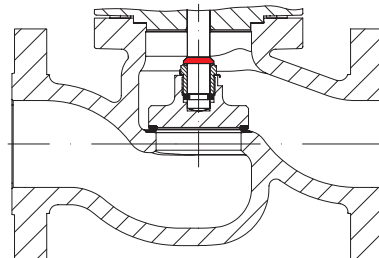
Limit switch, mechanic  
(special limit switches on request)



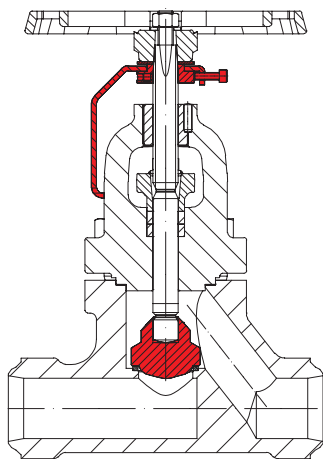
Tamper resistant  
handwheel blocking



Stem extension  
(please specify height in your order)

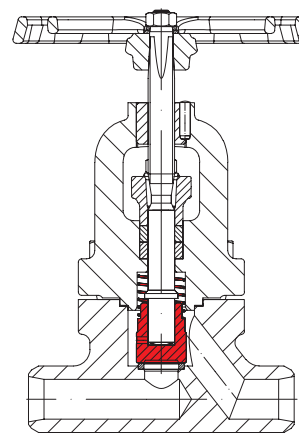


DN65-100: Back seat (when fully opened valve)  
DN10-50: standard



DN10-50: Regulating plug with position indicator and locking device  
(for max. permissible  $\Delta P$  refer to: Flow diagram)

DN65-100: on request

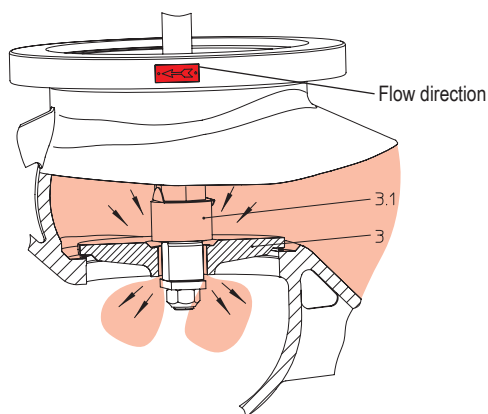


DN10-50: Screw down non-return plug with re-setting spring

DN65-100: on request

Set pressure 0,15 bar

Flow values (Kvs and Zeta) refer to data sheet „Check valves“.



Balancing plug

Valves with balancing plugs have to be installed with medium **flowing over the plug (3) as indicated by flow** direction arrow on valve body.

Working principles:

When the valve is closed, anticlockwise rotation of the hand wheel lifts the pilot plug (3.1) off the larger balancing plug (3).

This allows the medium to pass through the plug and equalizes the pressure of the medium under the plug (3). After the pressures have been equalized within the values stated in the table, the valve can be opened by turning the valve further with normal manual force.

Balancing plugs are fully effective only in closed systems.

The pressures of the medium on either side of the plug can not be equalized if the medium is discharged into open air.

A bypass line or some other arrangement is necessary if too much time is required for pressure equalization owing to the volume in the piping system.

**ARI-stop valves with differential pressures exceeding the following pressures, have to be fitted with pressure balancing plugs**

DN	65	80	100	125	150
Gauge press. ( $\Delta P$ ) (bar)	110	70	44	on request	

**Please indicate when ordering**

- Figure-No.
- Nominal pressure
- Nominal diameter
- Special design / accessories

**Example:**

Figure 46.006; Nominal pressure PN63; Nominal diameter DN50; with regulating plug with position indicator and locking device.

Dimensions in mm  
Weights in kg  
1 bar  $\hat{=}$  10<sup>5</sup> Pa  $\hat{=}$  0,1 MPa  
Kvs in m<sup>3</sup>/h



**Technology for the Future.**  
GERMAN QUALITY VALVES

ARI-Armaturen Albert Richter GmbH & Co. KG, D-33756 Schloß Holte-Stukenbrock,  
Tel. +49 52 07 / 994-0, Telefax +49 52 07 / 994-158 or 159 Internet: <http://www.ari-armaturen.com> E-mail: [info.vertrieb@ari-armaturen.com](mailto:info.vertrieb@ari-armaturen.com)